

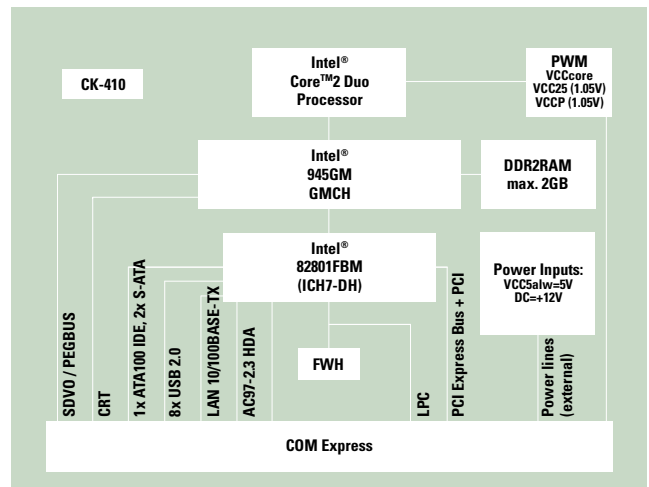

Passive cooler
Part no. 805370



Active cooler
Part no. 805371



SMX945 COM Express

Description

The smartModule SMX945-xxx is based on the Intel® Core™ Duo CPU with a clock speed of 2x 1600MHz. In addition to the properties of the SM855, it offers a faster CPU, PCI Express, 2x SATA, 8-channel sound output and an accelerated video controller. The product is characterized by the efficient thermal interface and large number of interfaces. The copper core conveys, with negligible loss, the thermal output to the heat dissipator and housing. The robust, flat-ground housing protects the computer from vibrations and holds the SO-DIMM RAM module firmly in the base. The SMX945 is the smallest Core™2 Duo computer and fits, for example, on a PC/104 standard board.

Applications

- _ Networked interactive multimedia applications
- _ Dual screen applications
- _ Picture recognition
- _ Measurement engineering
- _ Media center, extender

Ordering information (Option/accessories)

Article	No.	Description
SODIMM DDR2 256MB	890674	200pin, 533MHz, noECC
SODIMM DDR2 512MB	890675	200pin, 533MHz, noECC
SODIMM DDR2 1GB	890676	200pin, 533MHz, noECC
SODIMM DDR2 2GB	890677	200pin, 533MHz, noECC
SMX-CON8	807138	Connector 220pin, h=8mm, 2 needed, packsize=90
SMX945-DK	805390	SMX945 DevelopmentKit without SMX945 and RAM, HD, CD, Doc's,Cables,PS, w.passive & active cooler
SMX9/G45 passive cooler	805370	incl. assemblymat.
SMX9/G45 active cooler	805371	incl. assemblymat.

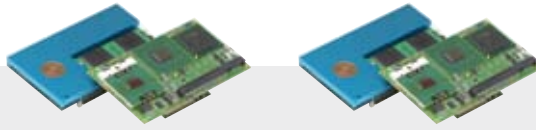

Technical data

Type	SMX945-L2400	SMX945-L7400
CPU	Intel® Core™ Duo L2400	Intel® Core™2 Duo L7400
ISA-BUS	-	-
PCI-BUS	32bit	32bit
PCI Express-BUS	6x 1 lane	6x 1 lane
2 nd Level cache (kB)	2048	4096
Performance (MHz)	2x 1600, FSB667	2x 1500, FSB667
DRAM Min-Max (MB)	256-2048	256-2048
CompactFlash socket	-	-
Keyboard, mouse (PS/2)	ext. SIO	ext. SIO
Boot drive	FD, HD, USB, LAN	FD, HD, USB, LAN
Floppy interface	ext. SIO	ext. SIO
IDE interface P-ATA	1x	1x
IDE interface S-ATA (300Mbit/s), RAID 0/1	2x	2x
COM1	ext. SIO	ext. SIO
COM2	ext. SIO	ext. SIO
COM3	-	-
COM4	-	-
LPT1	ext. SIO	ext. SIO
USB (2.0)	8x	8x
LAN port 1 (ext. transformer)	10/100BASE-T	10/100BASE-T
LAN port 2	-	-
Audio	HDA-7.1, 192kHz	HDA-7.1, 192kHz
Video controller	i945GME	i945GME
Video memory (MB)	8-224 (UMA)	8-224 (UMA)
LCD interface	ext. 18bit LVDS	ext. 18bit LVDS
DVI interface	ext. 2x SDVO	ext. 2x SDVO
CRT interface	yes	yes
AMT 4.0	-	-
Watchdog	yes	yes
Power normal (typ.)	20W, 12V	24W, 12V
Power suspend (typ.)	0.1W	0.1W
Power management	yes, SpeedStep	yes, SpeedStep
RTC battery onboard	external	external
Cooling type	passive/active	passive/active
Operating temperature	-25°C to +70°C	-25°C to +70°C
Extended operating temperature (E47)	-40°C to +70°C	-40°C to +70°C
Size (W x L x H in mm)	117 x 70 x 18	117 x 70 x 18
Weight	175 g	175 g
MTBF	>200'000h	>200'000h
Special features 1	-	-
Special features 2	-	-
Special features 3	-	-
Part no. (without DDR2RAM-module)	805350	805352

Manufacturer:

DIGITAL-LOGIC
smart embedded computers

DIGITAL-LOGIC | Nordstrasse 11/F | CH-4542 | Luterbach / Switzerland
Phone +41 (0)32 681 58 00 | Fax +41 (0)32 681 58 01
sales@digitallogic.com | www.digitallogic.com

Distribution: